

**USER MANUAL**

**START HERE**

# SF5

## **SMITH MACHINE FUNCTIONAL TRAINER**

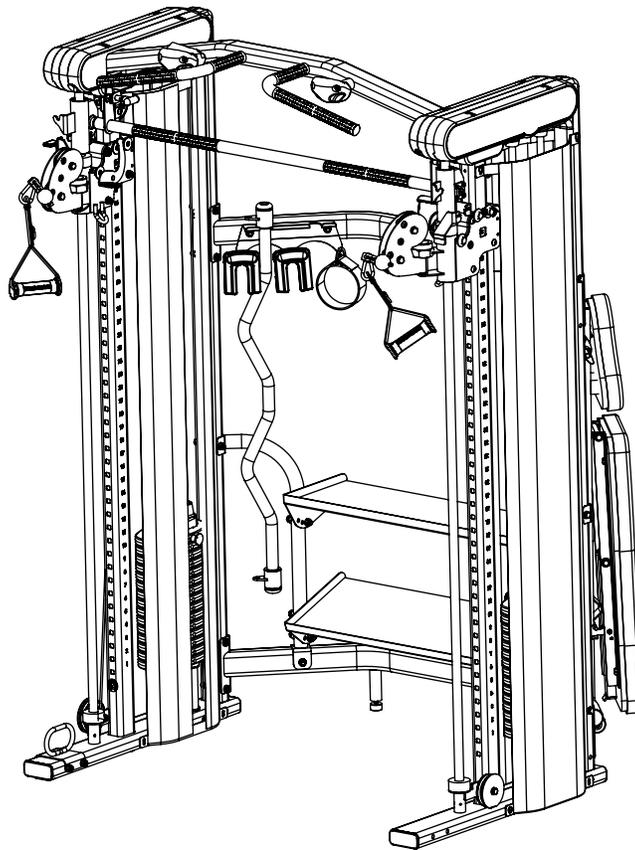

Machine shown with optional bench and rack attachment

Record Serial Number Here

Health in Motion LLC  
V09222023



## CONGRATULATIONS

Welcome to the Inspire Fitness Family. You've just taken the first step to a healthier and stronger body. This SF5 Smith Machine Functional Trainer by Inspire Fitness offers the key to unlocking your body's potential. Regular training on a Smith Machine Functional Trainer has been shown to deliver a host of benefits including: increased muscle tone, decreased body fat, improved energy levels, and a reduction in stress. Congratulations, you are on your way to improving your self image, overall health, and quality of life.

## BEFORE ASSEMBLING YOUR SF5

**IMPORTANT:** Read this entire manual before attempting to build or use this machine. This manual contains step by step instructions for proper assembly.

Use the parts list included in this manual to verify that all parts are accounted for before assembly. If any parts are missing, contact Inspire Fitness Support for replacement parts through email, by phone or through chat.

This Inspire Fitness SF5 Smith Machine Functional Trainer is intended for indoor use only. Rust can form on certain parts in a humid environment, resulting in impaired function.

## CONTACT US FOR HELP

Service of your SF5 Smith Machine Functional Trainer should only be performed by an Inspire Fitness Authorized Servicer. Service performed by anyone else can result in loss of warranty. If you need help finding an Inspire Fitness Authorized Servicer, please contact us directly:



### Email

Hello@centr.com



### Phone

+1 877-738-1729 (US Only)

+1 714-738-1729 (Global)

Mon-Fri 8am-5pm PT - UTC-7h/8h

***\*Support is provided in English and Spanish\****



### Chat

www.inspirefitness.com

## **TABLE OF CONTENTS**

PRODUCT WARRANTY.....	5
IMPORTANT SAFETY NOTICE.....	5
ASSEMBLY AND SETUP.....	6
ASSEMBLY INSTRUCTIONS.....	10
FEATURES AND FUNCTIONS.....	19
LABEL PLACEMENT.....	20
LIVE AREA.....	21
PRODUCT DIMENSIONS.....	22
MAINTENANCE.....	23
EXPLODED VIEW.....	24
PARTS LISTS.....	25

---

## PRODUCT WARRANTY

To view full warranty details, or to register your product for warranty, visit [inspirefitness.com/support](https://inspirefitness.com/support)

### AUSTRALIA

Our goods come with guarantees that cannot be excluded under the Australian Consumer Law. You are entitled to a replacement or refund for a major failure and for compensation for any other reasonably foreseeable loss or damage. You are also entitled to have the goods repaired or replaced if the goods fail to be of acceptable quality and the failure does not amount to a major failure.

Our goods and services come with guarantees that cannot be excluded under the Australian Consumer Law. For major failures with the service, you are entitled:

- to cancel your service contract with us; and
- to a refund for the unused portion, or to compensation for its reduced value.

You are also entitled to choose a refund or replacement for major failures with goods. If a failure with the goods or a service does not amount to a major failure, you are entitled to have the failure rectified in a reasonable time. If this is not done you are entitled to a refund for the goods and to cancel the contract for the service and obtain a refund of any unused portion. You are also entitled to be compensated for any other reasonably foreseeable loss or damage from a failure in the goods or service.

## IMPORTANT SAFETY NOTICE

### PRECAUTIONS

This exercise machine is built for optimum safety. However, certain precautions apply whenever you operate a piece of exercise equipment. Be sure to read the entire manual before you assemble or operate your machine. Please note the following safety precautions:

1. **Consult your physician before beginning any exercise program**
2. Always keep children and pets away from the machine. **DO NOT** leave children unattended in the same room with the machine. The cabling and moving parts on this machine can cause serious injury or death if used improperly.
3. Only one person at a time should use the machine.
4. If the user experiences dizziness, nausea, chest pain, or any other abnormal symptoms, **STOP** the workout at once. **CONSULT A PHYSICIAN IMMEDIATELY.**
5. Position the machine on a clear, leveled surface. **DO NOT** use the machine near water or outdoors.
6. Keep hands away from all moving parts.
7. Always wear appropriate workout clothing when exercising. **DO NOT** wear robes or other loose clothing that could become caught in the machine. Running or training shoes are also required when using the machine.
8. Use the machine only for its intended use as described in this manual. **DO NOT** use attachments not recommended by the manufacturer.
9. **DO NOT** place any sharp objects around the machine.
10. Disabled persons should not use the machine without a qualified person or physician in attendance.
11. Before using the machine to exercise, always do stretching exercises to properly warm up.
12. Never operate the machine if the machine is not functioning properly.

### Care and Maintenance

- Inspect and tighten all parts before using the machine.
- The Frame and Seat Pad of the machine can be cleaned using a damp cloth and mild non-abrasive detergent. **DO NOT** use solvents

**WARNING: BEFORE BEGINNING ANY EXERCISE PROGRAM, CONSULT YOUR PHYSICIAN. THIS IS ESPECIALLY IMPORTANT FOR INDIVIDUALS OVER THE AGE OF 35 OR PERSONS WITH PRE-EXISTING HEALTH PROBLEMS. READ ALL INSTRUCTIONS BEFORE USING ANY FITNESS EQUIPMENT. Health In Motion, LLC. DOES NOT ASSUME ANY RESPONSIBILITY FOR PERSONAL INJURY OR PROPERTY DAMAGE SUSTAINED BY OR THROUGH THE USE OF THIS PRODUCT.**

# ASSEMBLY AND SETUP

## Package Contents

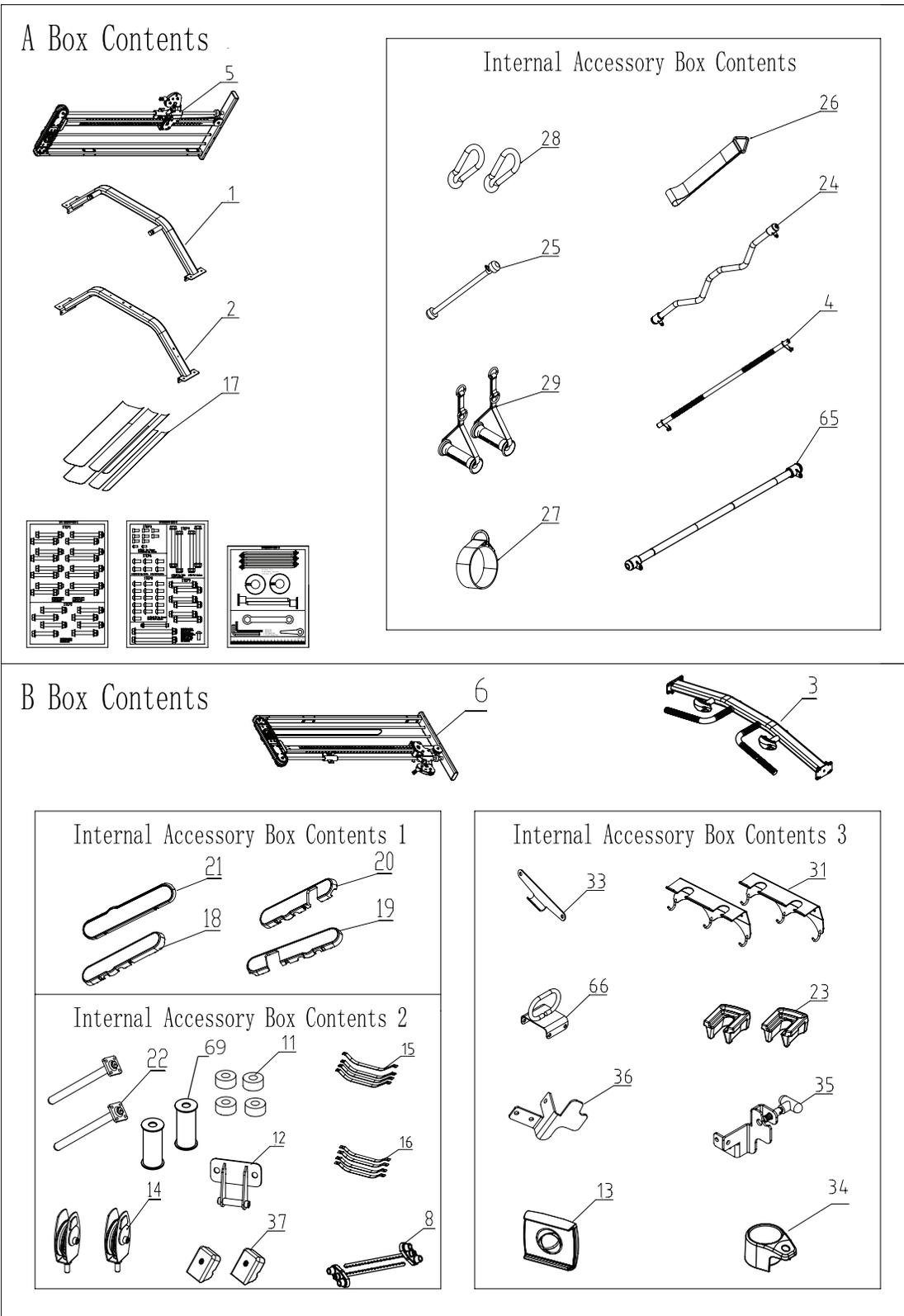

Assembly Hardware Kit (Not to Scale)

SF5 (GM6970-05)3-1

STEP1

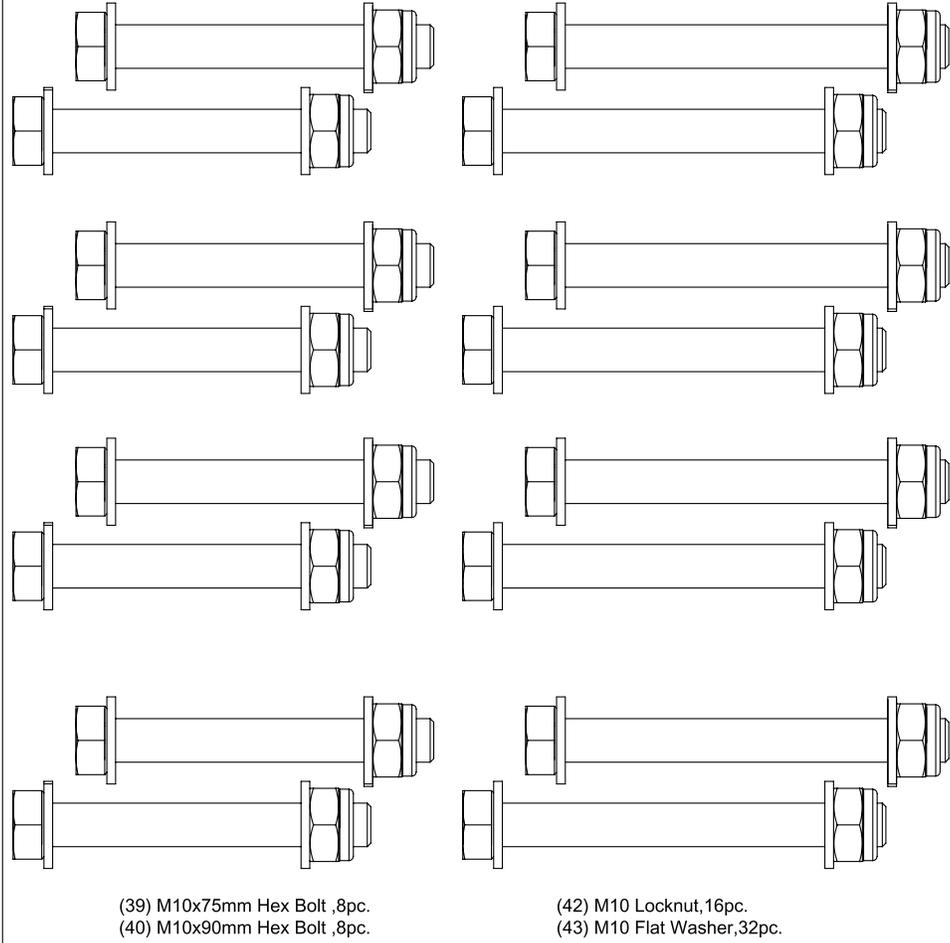

STEP2

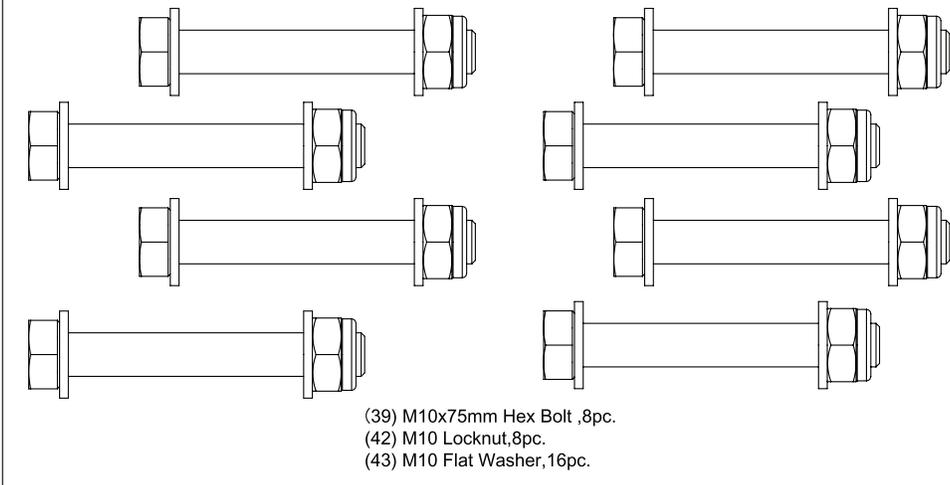

SF5(GM6970-05)3-2

**STEP3**

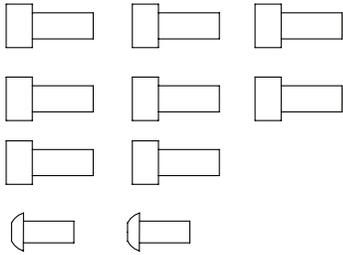

- (47) M6x14mm Allen Head Cap Screw,8pc.
- (50) M5x14mm Phillips Head Screw,2pc.

**STEP6**

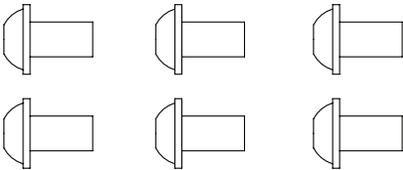

- (44) M8x16mm Button Head Cap Screw,6pc.
- (45) M8 Washer,6pc.

**STEP8**

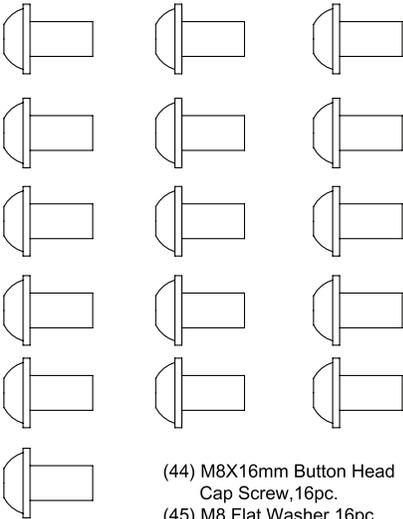

- (44) M8X16mm Button Head Cap Screw,16pc.
- (45) M8 Flat Washer,16pc.

**STEP4**

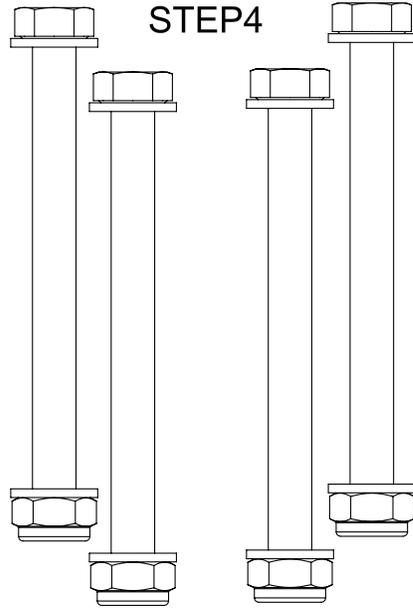

- (41) M10x115mm Hex Bolt,4pc.
- (42) M10 Locknut,4pc.
- (43) M10 Flat Washer,8pc.

**STEP9**

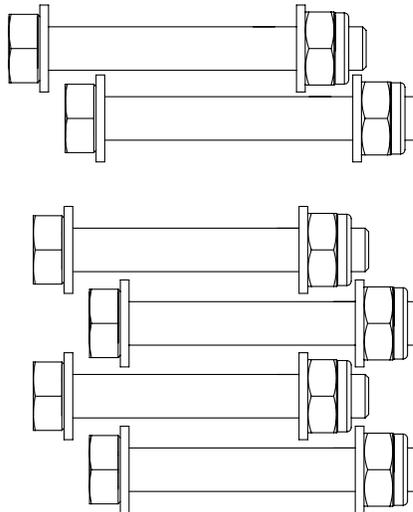

- (44) M8x16mm Button Head Cap Screw,1pc.
- (45) M8 Flat Washer,1pc.
- (39) M10X75mm Hex Bolt,2pc.
- (78) M10X70mm Hex Bolt,4pc.
- (43) M10 Flat Washer,16pc.
- (42) M10 Locknut,8pc.
- (46) M6X75 Allen Head Cap Screw,1pc.
- (48) M6 Flat Washer,2pc.
- (49) M6 Locknut,1pc.
- (74) M10X125mm Hex Bolt,2pc.

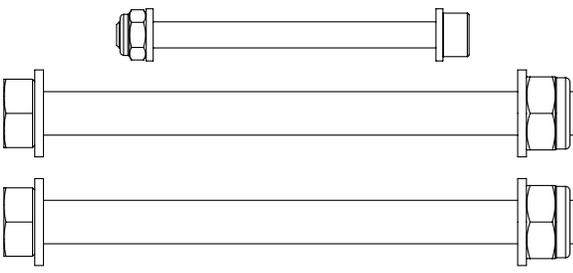



SF5(GM6970-05)3-3

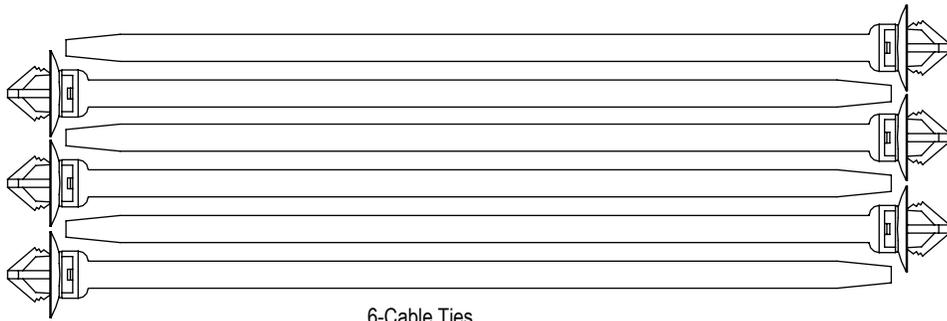

- 6-Cable Ties
- 2-Smithbar spacers
- 2-Weight Pin

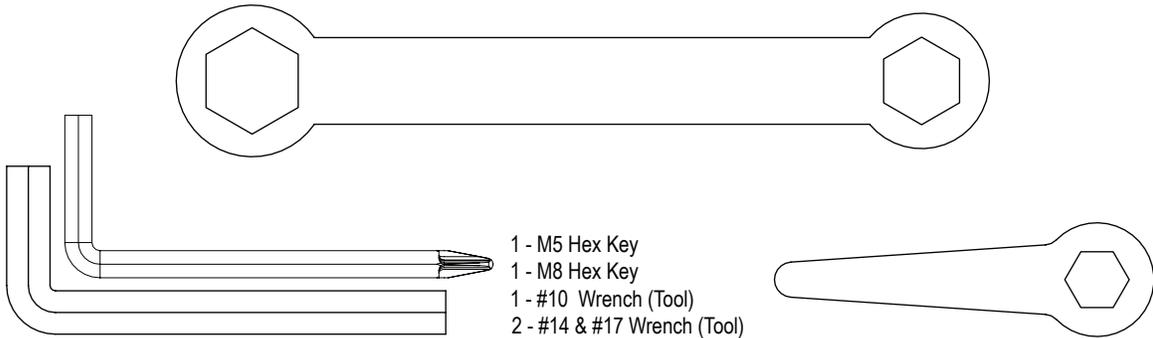
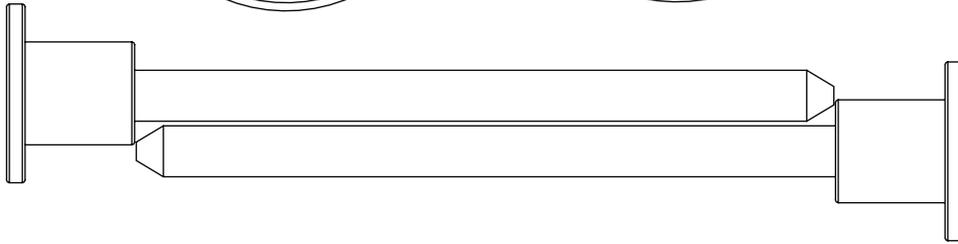
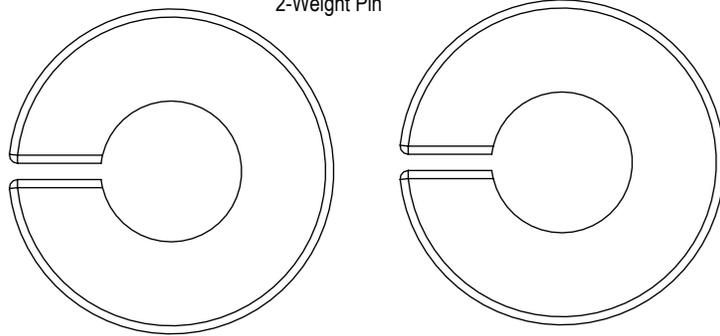

- 1 - M5 Hex Key
- 1 - M8 Hex Key
- 1 - #10 Wrench (Tool)
- 2 - #14 & #17 Wrench (Tool)

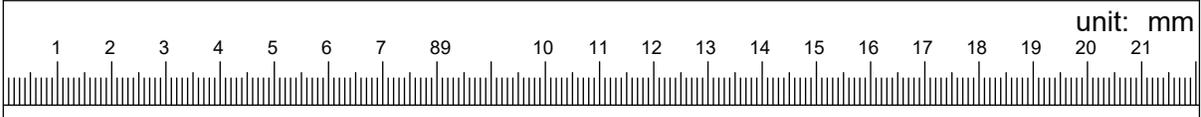

# ASSEMBLY INSTRUCTIONS

## STEP 1

**A.** Make sure any packing material or supports are removed from the frames prior to assembly. Start by placing the **Right Main Frame (6)** in the vertical position. Having a second person to hold the frame is helpful or you can possibly lean the frame against a wall. Insert two **M10x75mm Hex Bolts (39)** through the bottom **Lower Crossbar (1)** into the back of the **Right Main Frame (6)**, using **M10 Flat Washers (43)** on both sides and **M10 Locknuts (42)** hand tightened. Next insert two **M10x90mm Hex Bolts (40)** into the side of the bottom **Lower Crossbar (1)** and **Right Main Frame (6)**, using **M10 Flat Washers (43)** on both sides and **M10 Locknuts (42)** hand tightened.

**B.** Place the **Left Main Frame (5)** in the vertical position and align it with the lower rear **Lower Crossbar (1)**. Insert the hardware as described in the step above.

**C.** Repeat the steps above to attach the **Upper Crossbar (2)** to the **Right and Left Main Frames (6) (5)** similar to the lower **Lower Crossbar (1)** steps. **DO NOT TIGHTEN THE HARDWARE AT THIS TIME.**

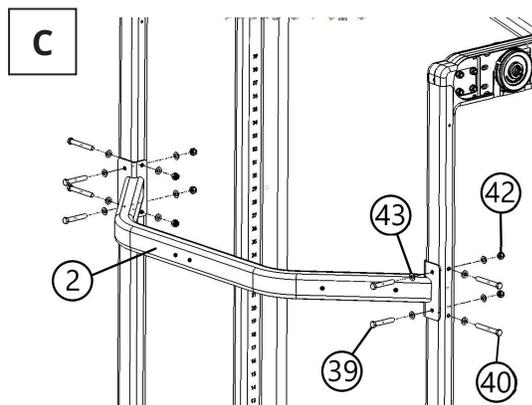
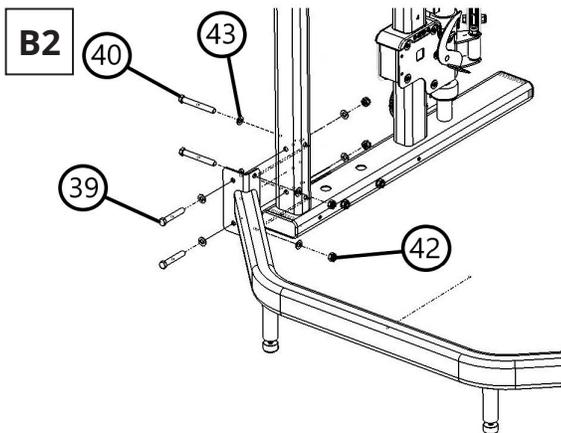
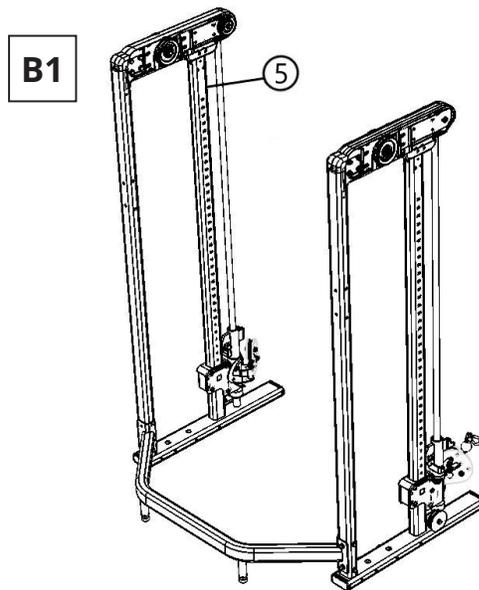
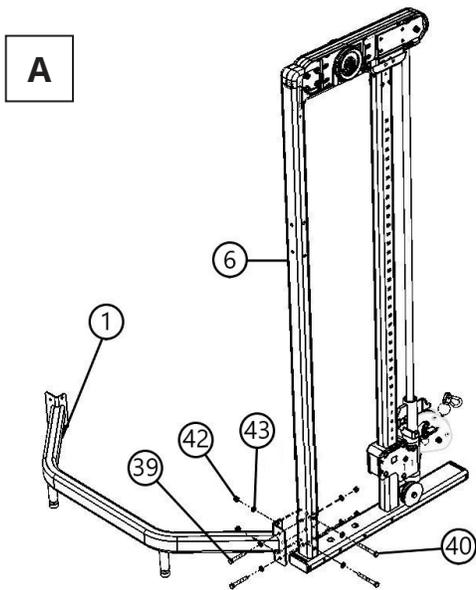

**STEP 2**

Place the **Pull-up Crossbar (3)** in position between the two main frames and insert four **M10x75mm Hex Bolts (39)** with **M10 Flat Washers (43)** through each main frame. Place **M10 Flat Washers (43)** and **M10 Locknuts (42)** onto the bolts. **DO NOT TIGHTEN THE HARDWARE AT THIS TIME.**

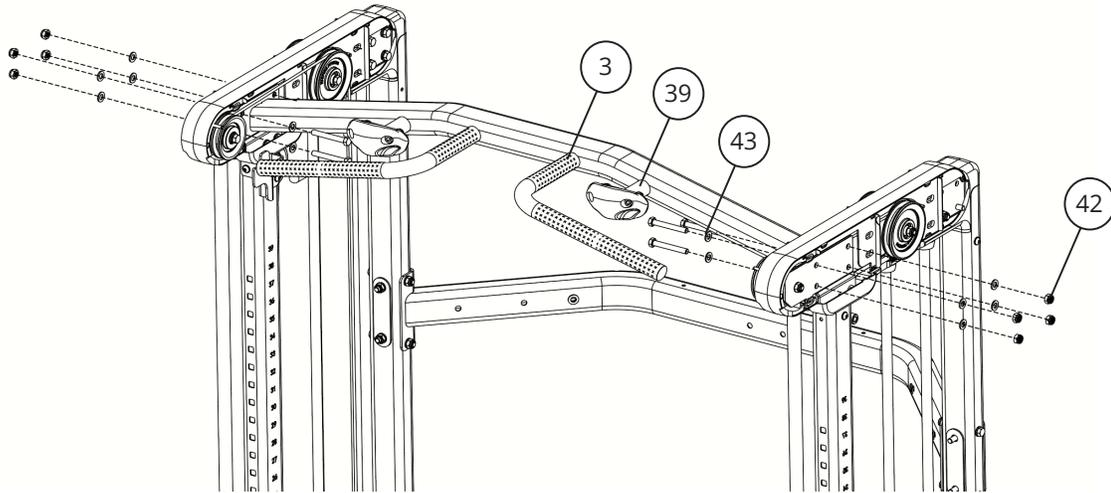

**STEP 3**

Lock the sliding carriages on the lowest (number 1) position. Place the **Smith Bar (4)** in between the rail slide mounts of the frame. Make sure the through hole on the tabs of the bar is positioned as shown. Insert the **Smith Bar Pins (22)** through both the **Right, Left Smith Bar Sliders (60), (62)** and into either end of the **Smith Bar (4)**. Use four **M6 Allen Head Screws (47)** on both sides to secure the **Smith Bar Pins (22)** to the **Smith Bar Sliders (60), (62)**. Next place the plastic **Smith Bar End Caps (37)** over the **Smith Bar Pins (22)** and secure with one **M5x14mm Phillips Head Screw (50)** per side. Make sure the machine is on level ground and **proceed to tighten all hardware installed in steps 1-3.** Adjust the two rear feet if needed to level the machine after tightening the hardware.

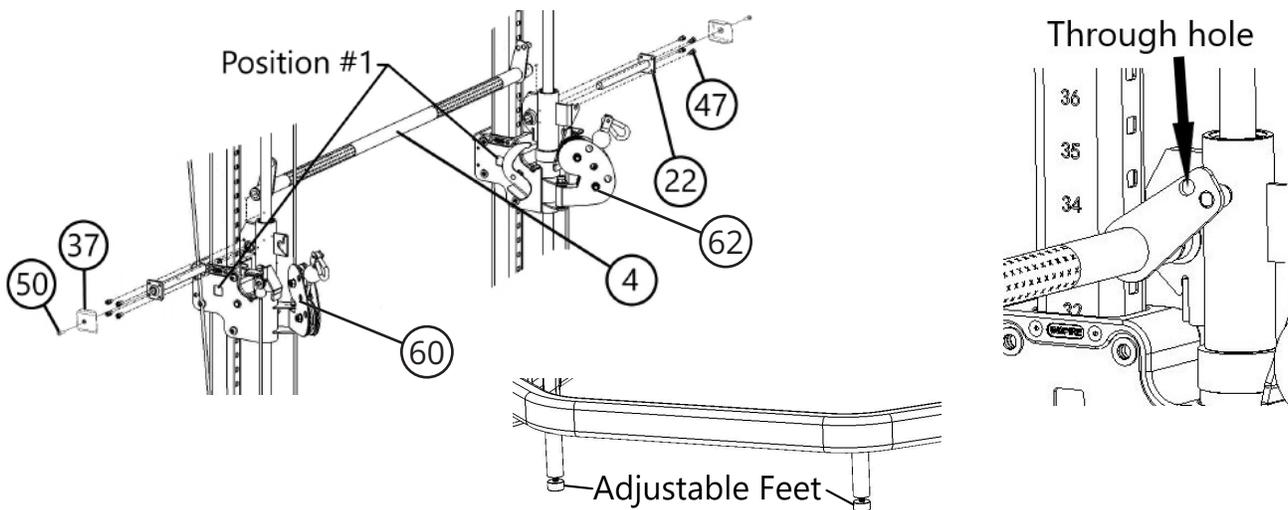

**STEP 4**

**A.** Thread the **Weight Stack Pulley (14)** into the top of both the **Top Plate Assembly (8)**, leave about a ¼ inch of thread.

**B.** Insert the **Weight Stack Guide Rods (7)** through the holes in the bottom of the frame. Be sure the ends of the rods with the holes are facing down, and do your best to align them with the holes in the frame. Then slide one **Weight Stack riser (69)** and one **Rubber Bumper (9)** down each of the guide rods.

**C.** Let the the **Weight Stack Guide Rods (7)** rest at an angle in the frame. Using the provided lubricant, spread the liquid up and down the guide rods. Then slide on 15 **Weight Stack Plates (9)** with the sticker cut out facing towards the inside of the machine and the protruding pads on the weights facing downward. Next slide on the **Top Plate Assembly (8)** assembly. Slide on the **Guide Rod Bushings (10)**, one on each rod, the tapered end of the bushing points downward. Repeat this step for the opposite side.

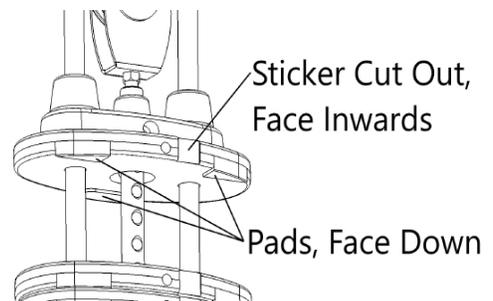
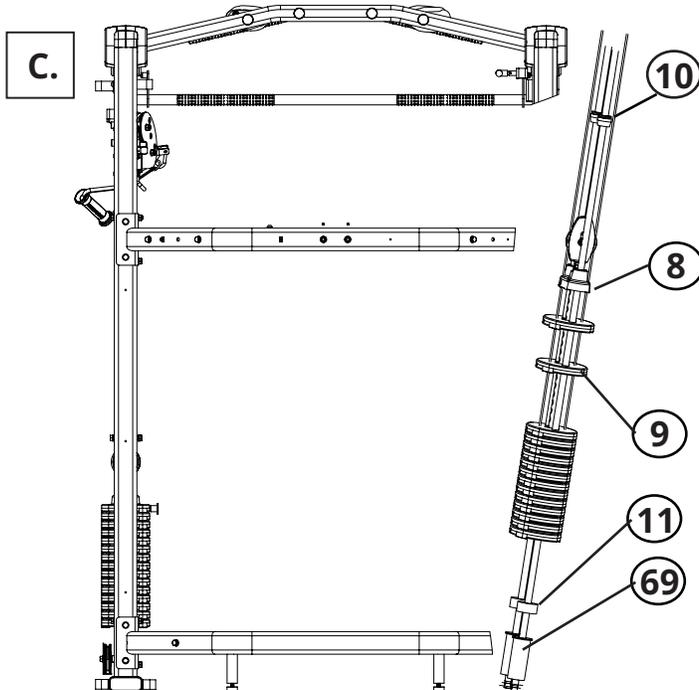
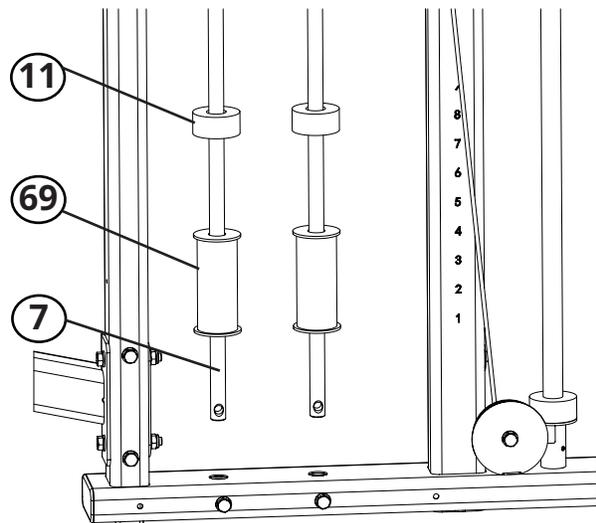
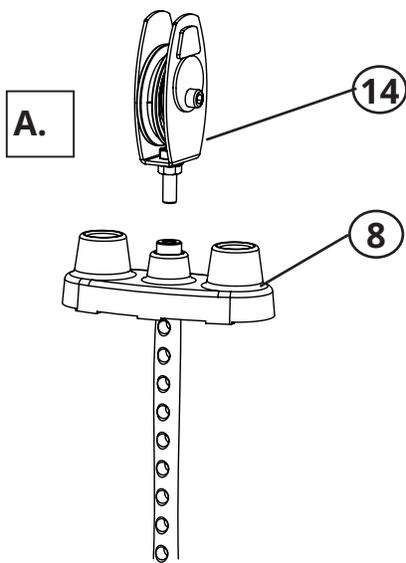

**STEP 4 (Continued)**

**D.** Make sure the cable that runs from either side of the frame is positioned between the two guide rods. Carefully pull the guide rods toward each other, then slide the **Guide Rod Bushings (10)** up into the larger hole of the frame until the slot of the bushing is resting in the frame. Next pull the bushings along with the rods away from each other so that the bushings slide into the smaller hole of the frame, thus locking them in place. The guide rods should be parallel to one another at this point.

**E.** Slide the **Weight Stack Guide Rods (7)** up so that the holes in the bottom of the rods align with the holes in the bottom of the frame. Insert two **M10x115mm Hex Bolts (41)** with **M10 Flat Washers (43)** through the frame and holes in the bottom of the rods. Place **M10 Flat Washers (43)** and **M10 Locknuts (42)** onto the bolts and tighten them. Repeat this step for the opposite side.

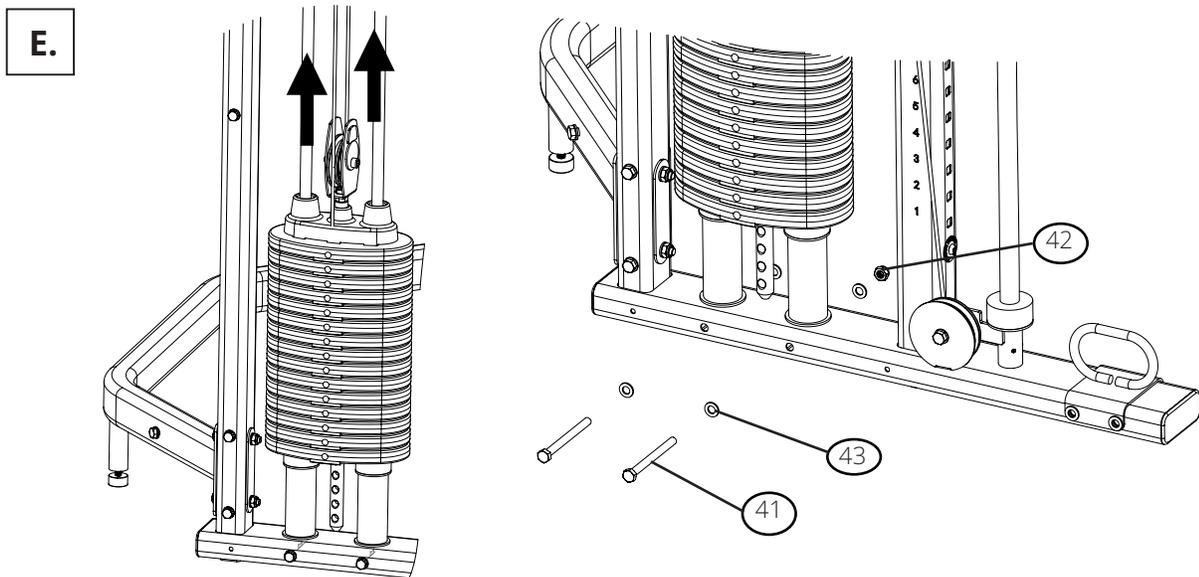
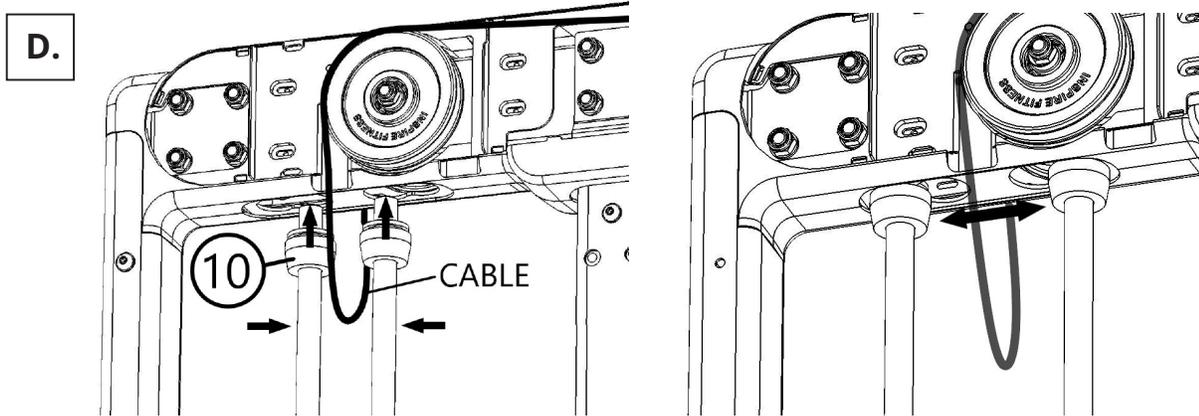

**STEP 5**

**A.** Route the cable as shown. Remove the pulley from the **Weight Stack Pulley (14)** assembly in order to route the cable into it, leave the hardware loose.

**B.** Adjust the cable tension by rotating the cam bolt until the **Top Plate Assembly (8)** starts lifting slightly from the weight stack. Tighten the nut of the cam bolt to lock it's position. Then tighten the jam nut at the base of the pulley.

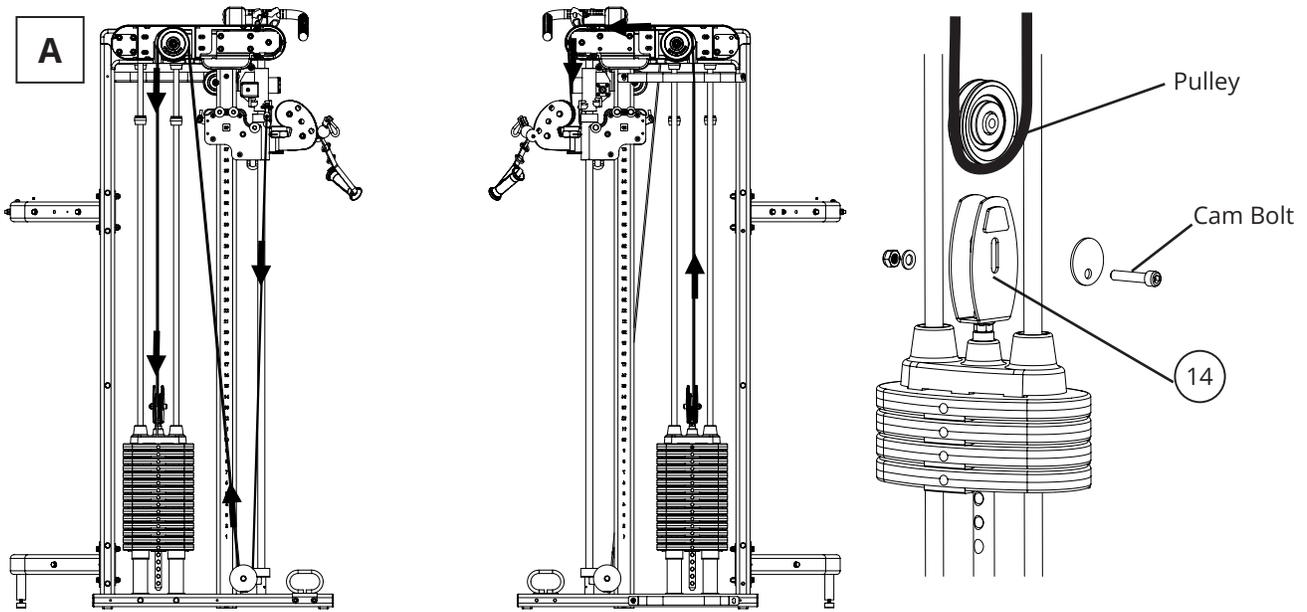

**B**

*Position the pulley to be perpendicular to the guide rods.*

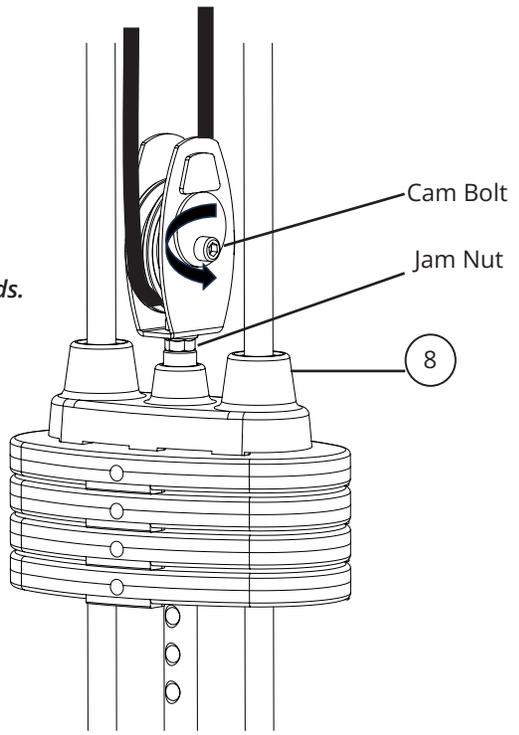



**STEP 8**

There are three different widths of weight stack shrouds. The widest **Shroud (17)** is placed on the outside facing part of the weight stack, the **Medium (17)** and **Narrow (17)** width shrouds are placed together on the inside, with the smaller placed toward the back of the machine. The mounting plates for them will be marked identifying the **Top Shroud Plate (15)**, **Bottom Shroud Plate (16)** and the forward direction of them, slide the plates through the pockets of the shrouds. Before applying the inner shrouds, apply the weight plate stickers. The number 1 sticker will go on the top plate, but we recommend that you start with the number 2 sticker. Place the number two sticker on the first weight plate. Then, apply the number 1 to the top weight plate assembly, using the #2 sticker to align it properly. Finish applying the stickers through #16. Secure the weight shrouds with **M8 x 16mm Button Head Cap Screw (44)** with **M8 Washers (45)** through the mount plates to the frame.

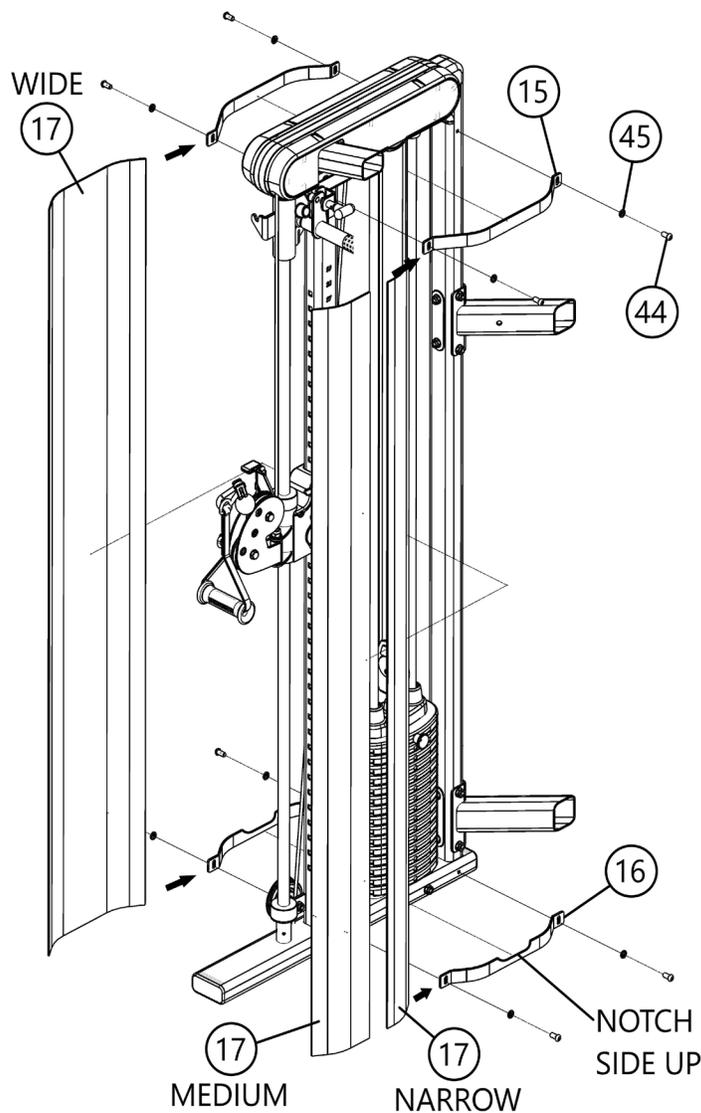



## STEP 9

**A.** Place the **Accessory Rack (31)** on right side of the **Upper Crossbar (2)**. Insert two **M10 x 75mm Hex Bolts (39)** with **M10 Flat Washers (43)** through the rack and crossbar. Place **M10 Flat Washers (43)** and **M10 Locknuts (42)** onto the bolts. Tighten the hardware.

**B.** Place the **Accessory Rack #2 (31)** on Left side of the inside of the **Upper Crossbar (2)**. On the back side of the tube, Place the **Bench Mount (33)** Insert two **M10 x 75mm Hex Bolts (39)** with **M10 Flat Washers (43)** through the rack and crossbar. Place **M10 Flat Washers (43)** and **M10 Locknuts (42)** onto the bolts. Tighten the hardware.

**C.** Mount the **Tablet Mount (12)** in the middle of the **Upper Crossbar (2)**. Insert two **M10 x 75mm Hex Bolts (39)** with **M10 Flat Washers (43)** through the mount and **Upper Crossbar (2)**. Place **M10 Flat Washers (43)** and **M10 Locknuts (42)** onto the bolts, tighten the hardware. Place the Tablet Holder on to its mount and secure with a **M6x75mm Allen Head Cap Screw (46)** and **M6 Locknut (49)**, using **M6 Washers (48)** on both sides. Tighten hardware until tablet holder holds its position but can still be tilted up and down by hand. Note: The Tablet holder mount can be bolted up or down depending on if you want the tablet holder higher or lower.

**D.** Place the Cup **Holder (34)** on the left side **Upper Crossbar (2)**, insert one **Bolt (44)** with a **Flat Washers (43)** through the hole to fasten in place.

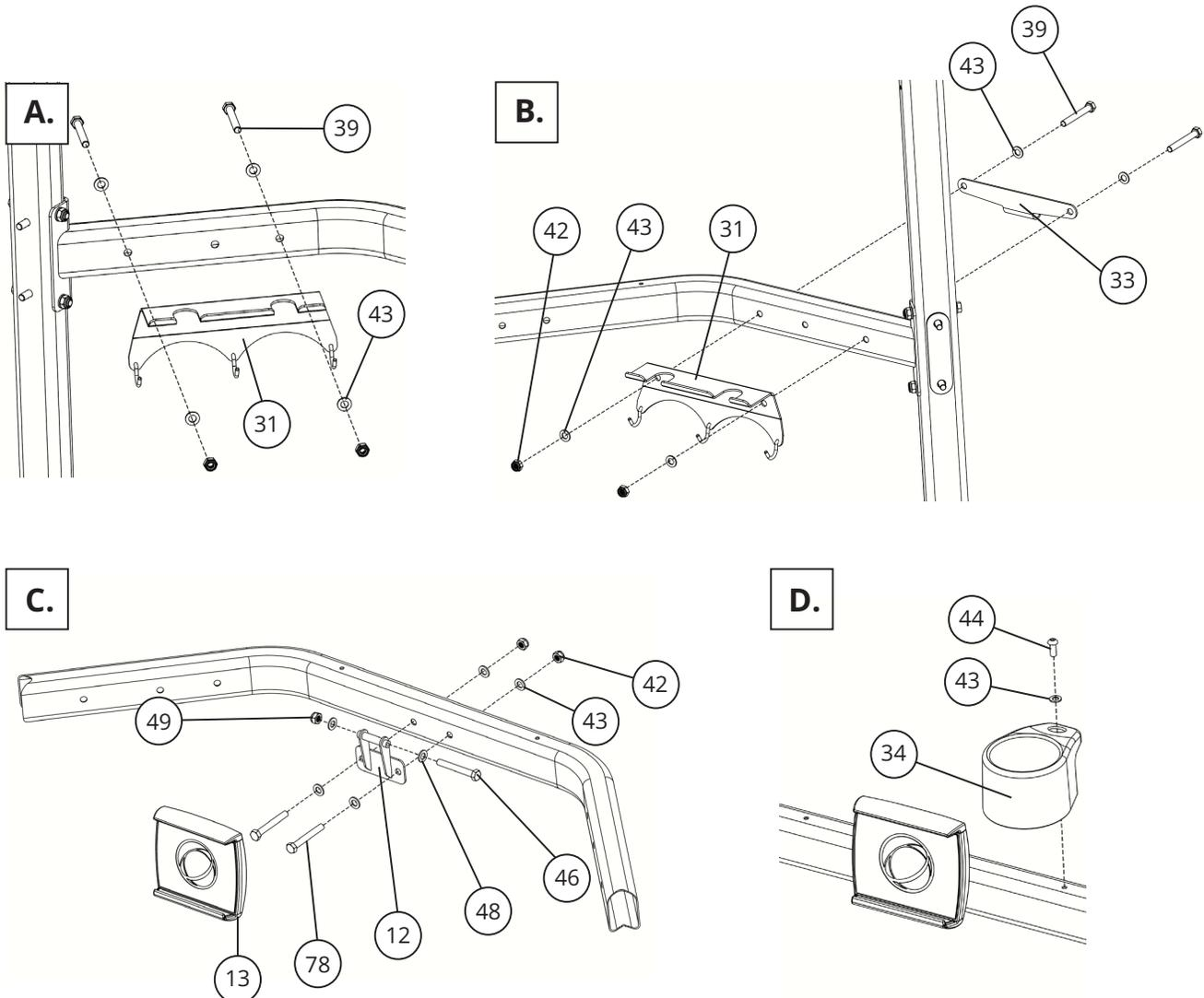

**STEP 9 (Continued)**

**E.** Place the **5 Lb Add On Weights (23)**, **Dual Hook Curl Bar (24)**, **Triceps Rope (25)**, **Chin/Dip Belt (26)**, and **Ankle Strap (27)**, on the accessory racks as shown. *Note: to use the 5 lb Add On Weight place them on top of the weight stacks in between the pullies.*

**F. Optional:** If you have electronics with cords, you can use the included **Cable Clips (55)** to route the cables along the frame of the machine

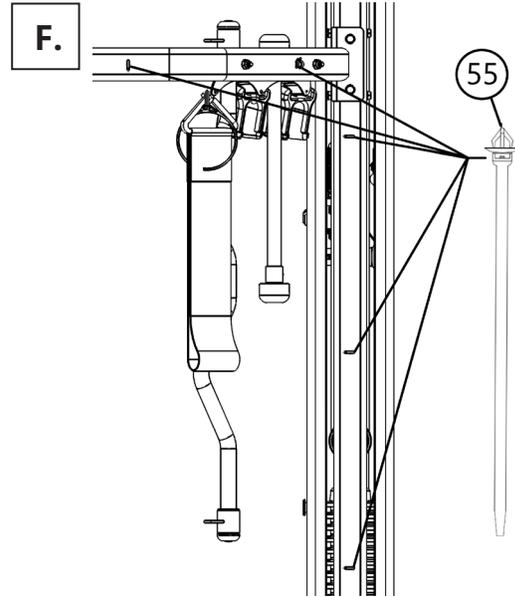
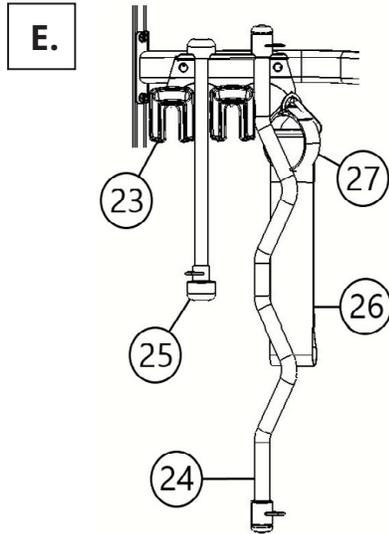

**IMPORTANT: Before use**

Remove bolts with labels that read **“REMOVE BEFORE USE”**. Located one per side as indicated. This will allow the carriage counterweights to move freely.

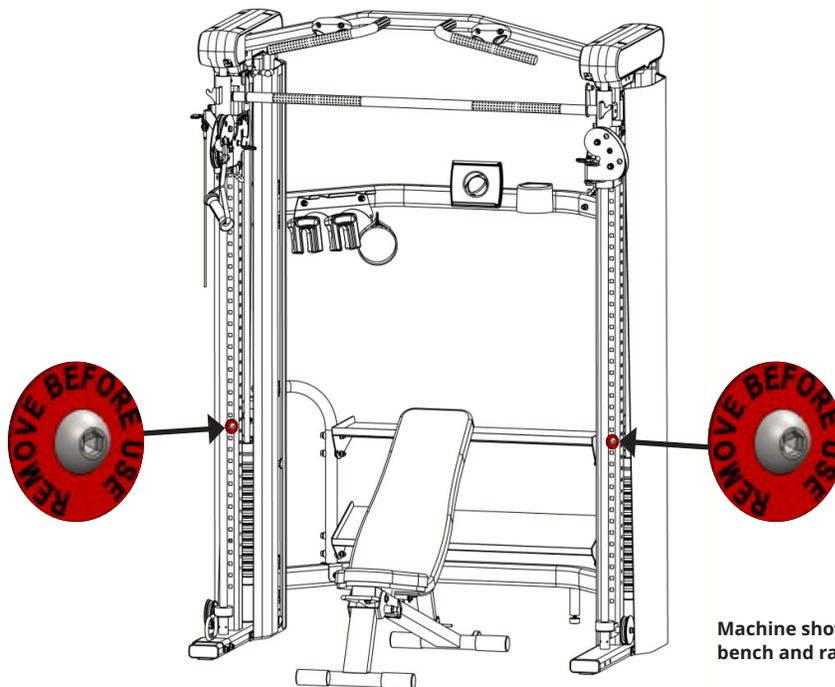

Machine shown with optional bench and rack attachment

# FEATURES AND FUNCTIONS

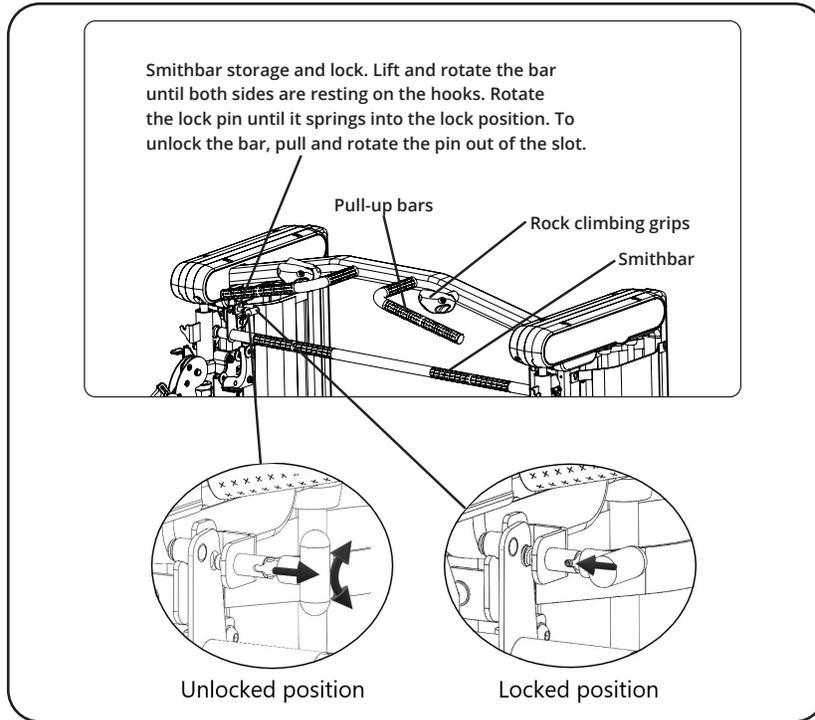

**⚠ WARNING** Securely lock the Smith Bar in the storage position whenever it is not in use. Be sure to use the lock pin.

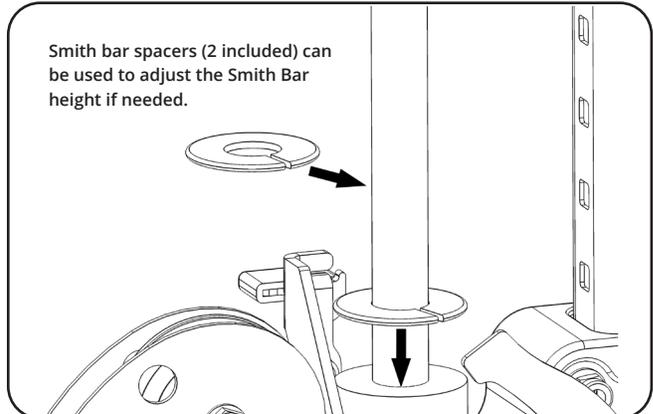
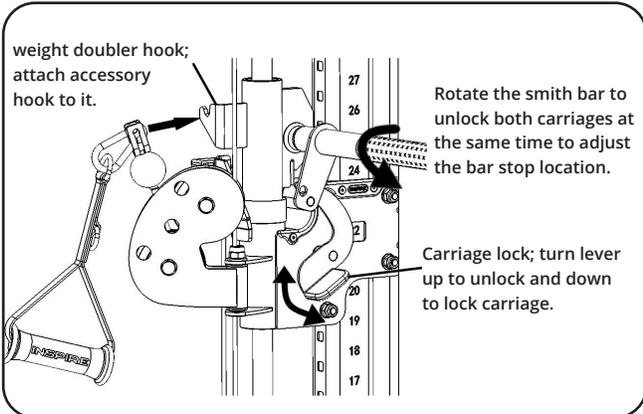
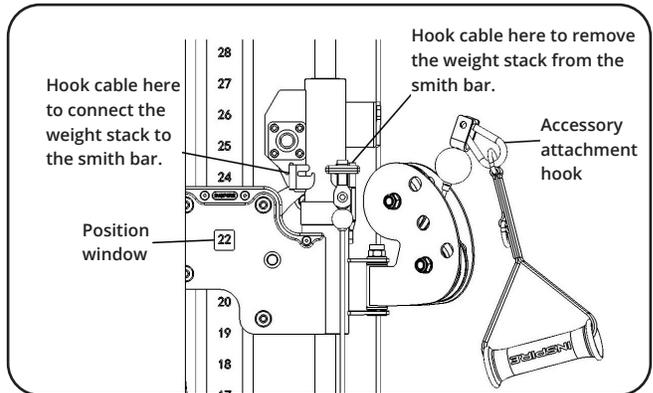
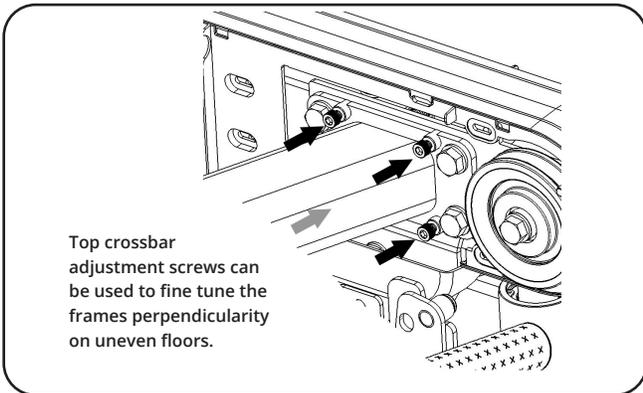



LIVE AREA

Machine shown with optional bench and rack attachment

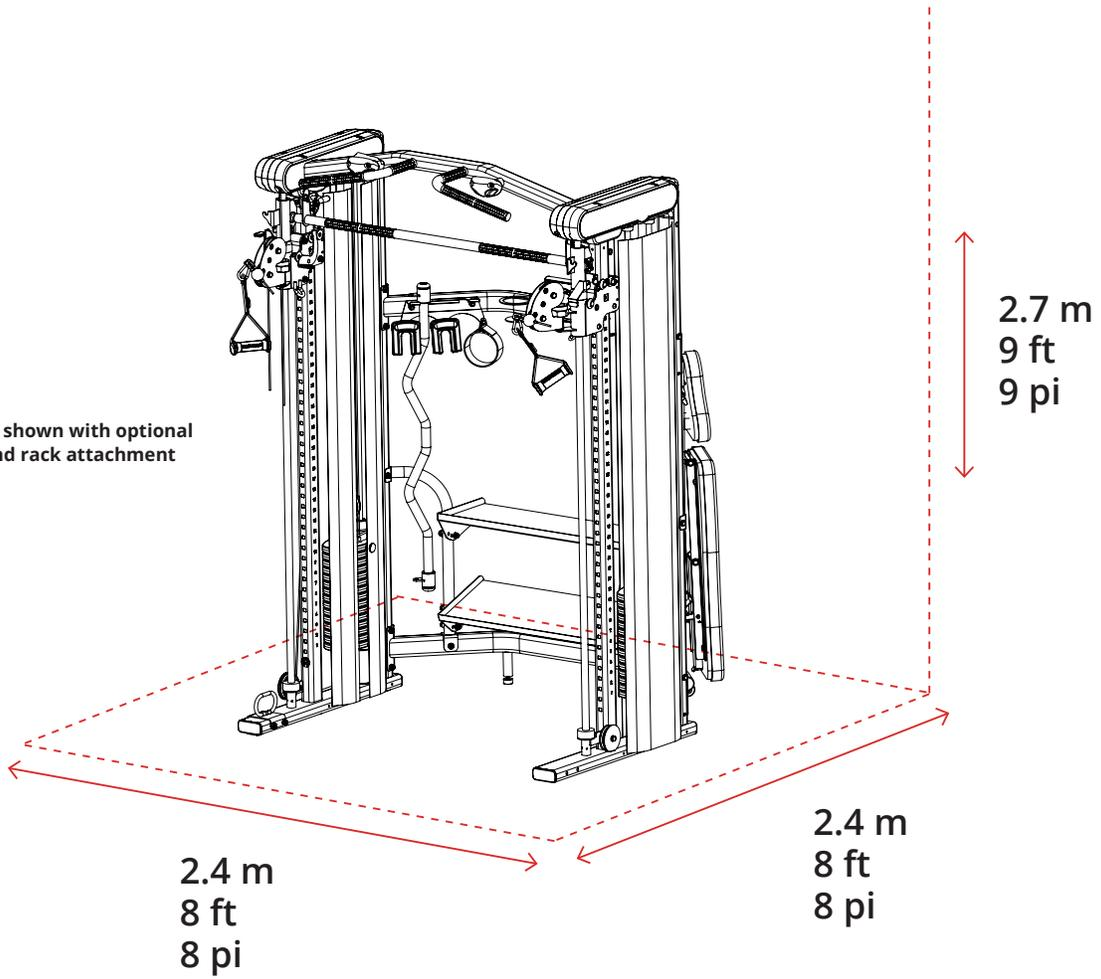

# PRODUCT DIMENSIONS

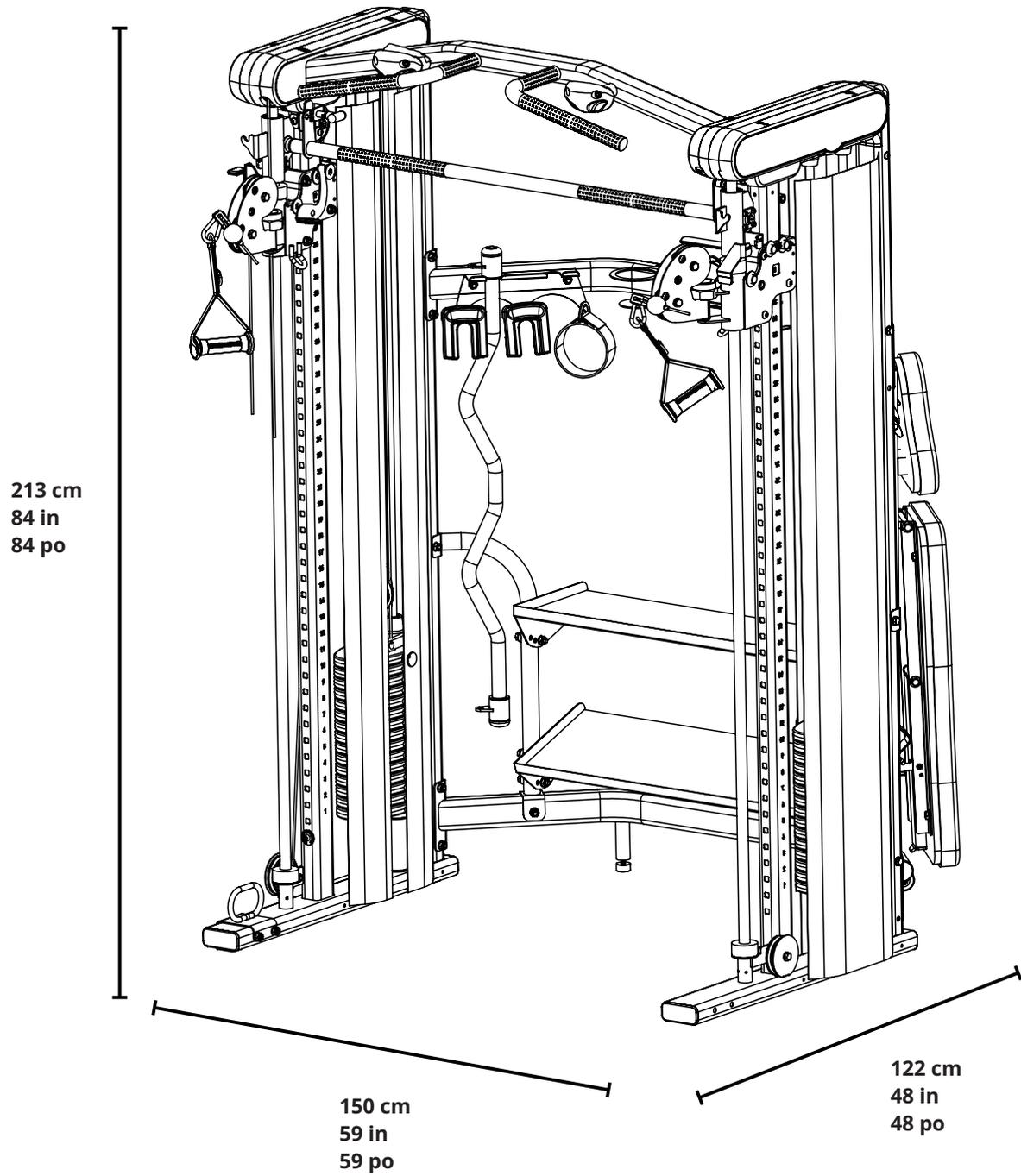

Machine shown with optional bench and rack attachment

## MAINTENANCE

### Warning

**DO NOT** place styrofoam or printed materials on the seat pads. Over time, these may stick to the pads and mar the surface.

**DO NOT** leave items sitting on the seat pads, these pads have a special density that takes shape to objects and small objects will leave imprints in the surface that may take time to come out.

- Periodically inspect the cables for splitting, cracking or fraying. Also watch for bulging or flat areas in the cable. **Pay particular attention to the cable ends.**
- Immediately replace cables at the first signs of damage or wear. Never use equipment with damaged or worn cables.
- Cables naturally stretch over time, so check cable slack periodically and adjust cable tension as needed.
- Regularly inspect product for loose hardware.
- Do not use or store equipment outdoors.
- Inspect snap links, swivels, handles and weight stack pin for wear or damage. If wear or damage exists, replace with Inspire Fitness parts only.
- Locate and familiarize yourself with all warning decals on the Smith Machine Functional Trainer.
- Replace damaged or worn upholstery immediately.
- Periodically wipe down guide rods with a dry cloth and re-apply a thin coat of a Teflon™ based lubricant.

# EXPLODED VIEW

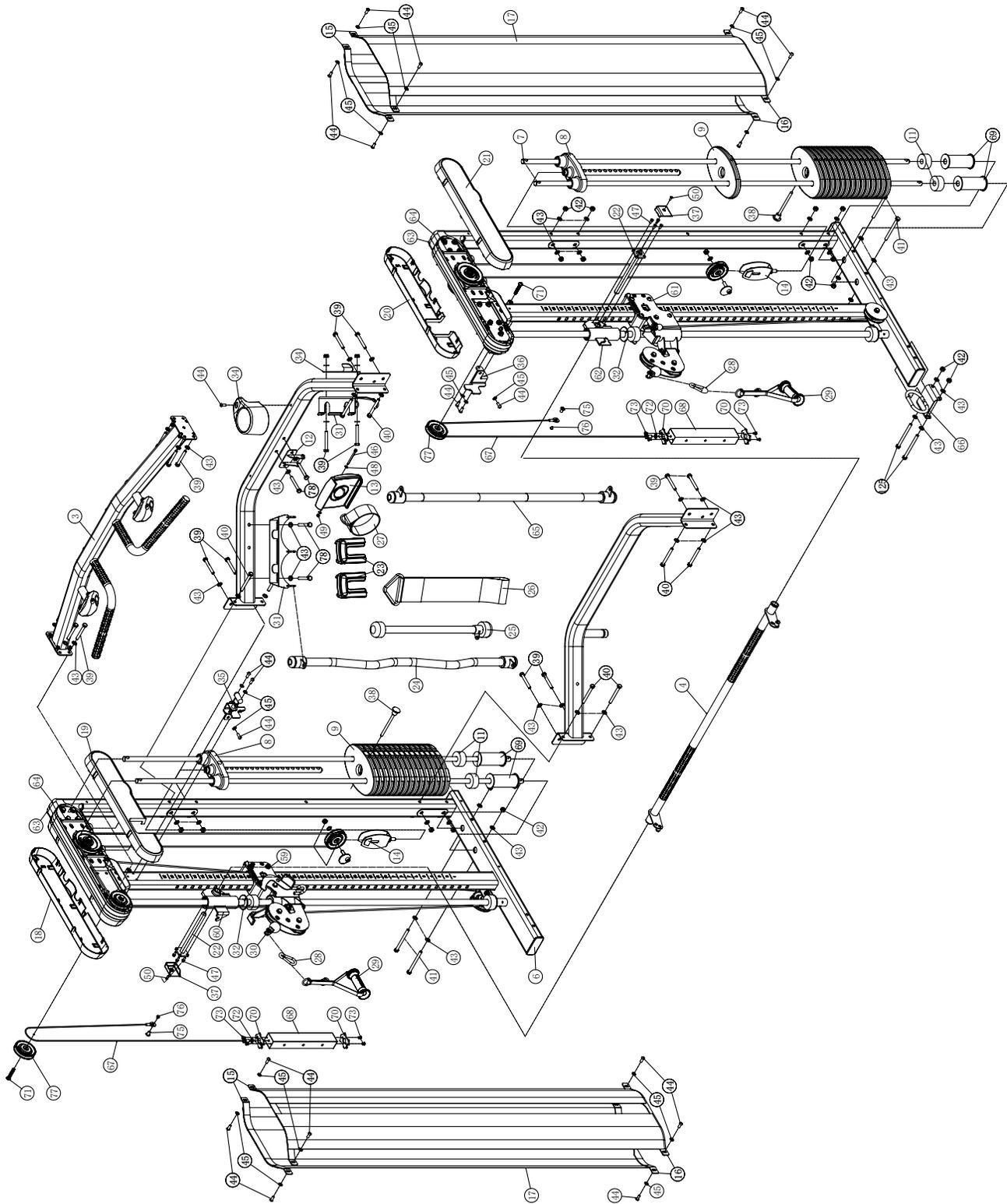



# PARTS LISTS

No.	Description	Part Number	Qty.
1	GM697260001PZ	Lower Crossbar	1
2	GM697260002PZ01	Upper Crossbar	1
3	GM697220003PZ	Pull-up Crossbar	1
4	GM697320004PZ01	Smith bar	1
5	GM697200010PZ	Left Main Frame	1
6	GM697200011PZ	Right Main Frame	1
7	GM697501001WX	Weight Stack Guide Rods	4
8	GM692500003PZ14	Top Plate Assembly	2
9	GM692-500-009	Weight Stack Plate	30
10	GM692-881-002	Guide Rod Bushings	4
11	GM692-881-003	Rubber Bumper	4
12	GM697260007PZ	Tablet Mount	1
13	BC423880109PZ05	Tablet Holder	1
14	GM692500002PZ04	Weight Stack Pulley	2
15	GM697321037PT0105	Top Shroud Plate	4
16	GM697321036PT0105	Bottom Shroud Plate	4
17	GM697-800-001	Wide, Medium, and Narrow Shrouds	2
18	GM697-881-003	Outer Right Plastic Cover	1
19	GM697-881-004	Inner Right Plastic Cover	1
20	GM697-881-005	Inner Left Plastic Cover	1
21	GM697-881-006	Outer Left Plastic Cover	1
22	GM697320007PZ	Smith Bar Pin	2
23	GM692-500-001	5 Lb Add-on Weight	2
24	GM691320003PZ02	Dual Hook Curl Bar	1
25	GM692-881-011	Triceps Rope	1
26	GM692-400-005	Chin/Dip Belt	1
27	GM690-880-002	Ankle Strap	1
28	GM697-561-018	Spring Clip	2
29	GM870-880-007SK	Single Handle	2
30	GM697500003PZ	Wire Rope Assembly	2
31	GM697260004PZ01	Accessory Rack	1
32	GM697-881-010RC	Smithbar spacers	2
33	GM697381008PZ	Bench Mount	1
34	GM697-881-011	Plastic cup holder	1
35	GM697320008PZ	Right Smithbar hook	1
36	GM697321018PZ	Left Smithbar hook	1
37	GM697881007RCPZ	Smith Bar End Caps	2
38	GM692500004PZ	Weight Pin	2
39	0111-010-758	M10X75 mm Hex Bolt	17
40	0111-010-908	M10X90 mm Hex Bolt	8

No.	Description	Part Number	Qty.
41	0111-010-058	M10X115 mm Hex Bolt	4
42	0110-710-008	M10 Locknut	33
43	0116-010-008	M10 Flat Washer	66
44	0113-208-168A	M8x16mm Button Head Cap Screw	23
45	0116-008-028	M8 Washer	22
46	0113-206-751	M6X75 Allen Head Cap Screw	1
47	0113-706-142	M6x14mm Allen Head Cap Screw	8
48	0116-006-019	M6 Flat Washer	2
49	0110-706-019	M6 Locknut	1
50	0113-105-148	M5x14mm Phillips Head Screw	2
51	0511-608-002	8# Allen Tool	1
52	AB290-561-002	5#80*30, Multi Tool	1
53	M330-561-002	14# & 17# Hex Wrench	2
54	AB160561002XWX	10# Allen Tool	1
55	GM697-891-102	Cable Tie	6
56	GM697580004PZ	Hardware Pack 1	1
57	GM697580005PZ	Hardware Pack 2	1
58	GM697580006PZ	Hardware Pack 3	1
59	GM697320013PZ	Right Carriage Assembly	1
60	GM697320006PZ	Right Smith Bar Slider	1
61	GM697320014PZ	Left Carriage Assembly	1
62	GM697320005PZ	Left Smith Bar Slider	1
63	GM697-881-001	Inner trim cover R	2
64	GM697-881-002	Inner trim cover L	2
65	GM691320004PZ03	Straight Bar	1
66	GM697300001PZ	Battle rope mount	1
67	GM697-500-001	Cable	2
68	GM697561011PT0105	Counter weight	2
69	GM692380001PT0105	Risers	4
70	GM697-881-015	Counter weight slider	4
71	0113-210-558A	M10*55 Buttonhead Cap Screw	2
72	0116-310-028	Spring washer	6
73	0113-306-128A	Hexagon socket countersunk head screw	8
74	0111-010-122	M10*125 Hex Bolt	2
75	GM695-561-016	Nut	4
76	GM695-561-017	Buttonhead Cap Screw	4
77	GM692-880-001	Pulley	12
78	0111-010-708	M10X70 mm Hex Bolt	4



[www.inspirefitness.com](http://www.inspirefitness.com)